

# CLYDESDALE

## SKID BASE SELF-ERECTING PORTABLE CONCRETE BATCH PLANT

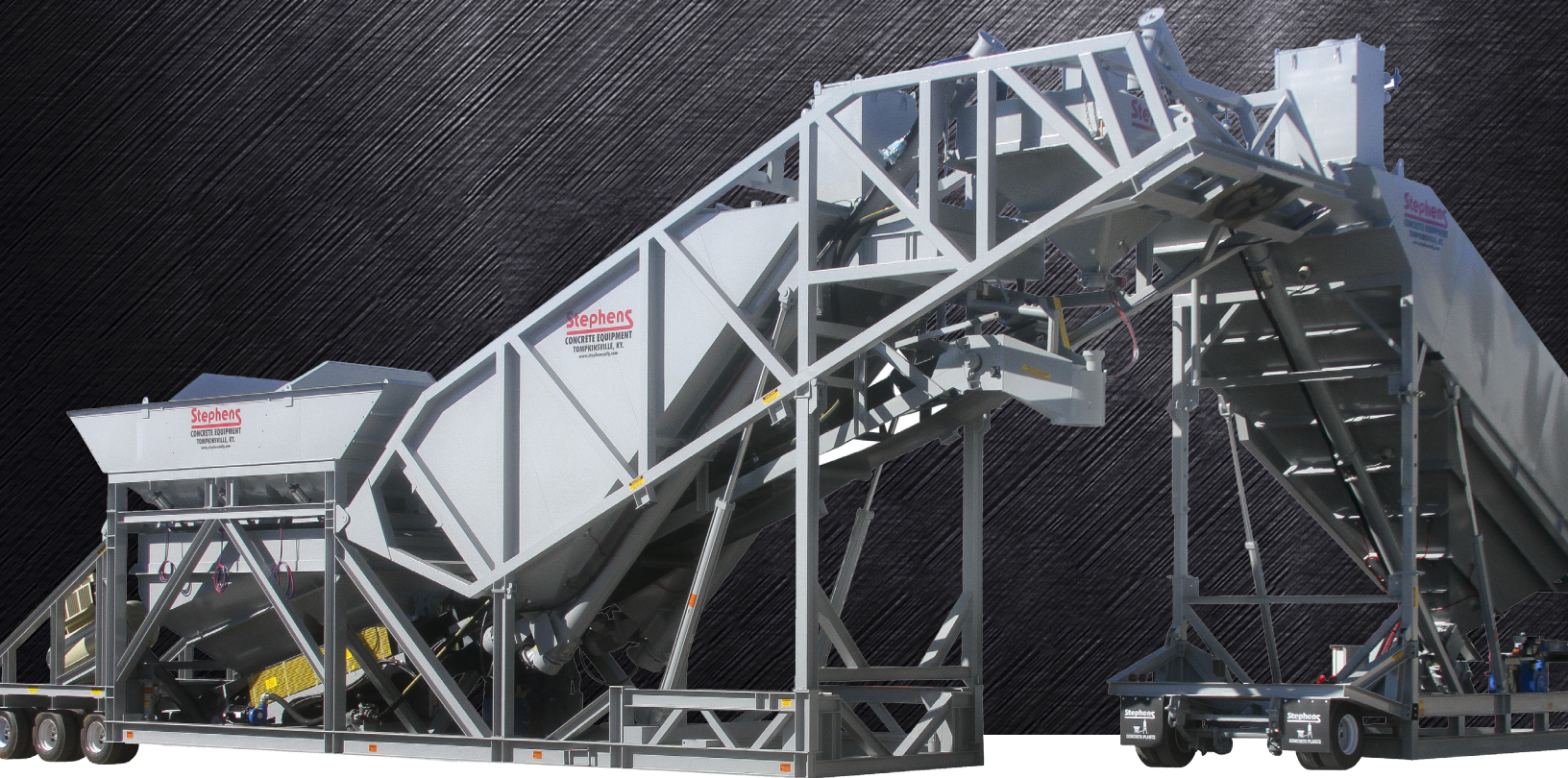

*shown with optional Pony Express Silo on right side*

Improve the quality and efficiency of your mobile batch plant operations with the new Stephens Clydesdale skid base system.

Specially designed features reduce the typical installation and operating costs and help increase your margins. You can count on Stephens for the highest quality equipment, service & support.

- Highly Portable 14' Travel Height
- Concrete Foundation May Not Be Required (*consult local engineer*)
- No Crane
- Up to 200 cy/hr
- Hydraulic Self-Erect

**Stephens**  
CONCRETE EQUIPMENT



Jamieson Equipment Company  
www.jamiesonequipment.com  
toll free 800.875.0280

# Skid Base Self-Erecting Portable Concrete Batch Plant Stephens Clydesdale

Highly portable heavy duty batch plant that will improve the quality and efficiency of your mobile operations. Concrete foundation may not be required.\* No crane needed because the unit can be installed with a standard loader and gin pole in combination with the hydraulic self erect systems. Accumulative and decumulative configurations.

**4** Permanently lubed gates.  
No grease required.

**5** Color coded air lines. En-  
closed Solenoid valves.  
5" cylinders.

**6** 15HP 240 gallon 51cfm  
air compressor.  
(Shown in travel position)

## 1 Standard Components

- Aggregate decumulative weighing or accumulative with 65 or 100 ton overhead bins\*\*
- 385 bbl cement silo with 4" fill lines
- Two standard 10" augers or optional high speed 12" augers
- 14 cubic yard cement batcher
- Standard 30" 20HP conveyor (623 tph) or 36" 30HP (1156 tph) conveyor with special discharge head
- Standard 3" Badger water meter
- 15HP 240 gallon 51cfm air compressor
- 200 amp enclosed power panel
- Tilt-away transportation system
- SOS 1020 cartridge silo dust collector
- SV20 filter bag batcher vent
- Gasoline engine driven hydraulic power pack
- Bolt-in 1/4" AR liners in discharge head
- Standard two air vibrators on aggregate batcher or adjustable electric vibrator
- Standard compressed air aeration or optional aeration blower
- Silo low level bin indicator
- 4 hydraulic levelling jacks
- Polyurethane blade belt wiper
- Made in Tompkinsville KY, USA
- *(accumulative plant shown)*

## 2 Optional Components

- 350 gallon water holding tank
- Water pump and water batcher
- 5" fill lines, or multiple fill lines
- 1/4" Brinell 400 AR liners in aggregate batcher and/or overhead bins
- Tilt-up silo collectors (350 bbl silo only)
- Pony Express 412 bbl Mobile Silo

**3** Optional high speed  
discharge head.



\* consult local engineer

\*\* 100 ton bins ship separately

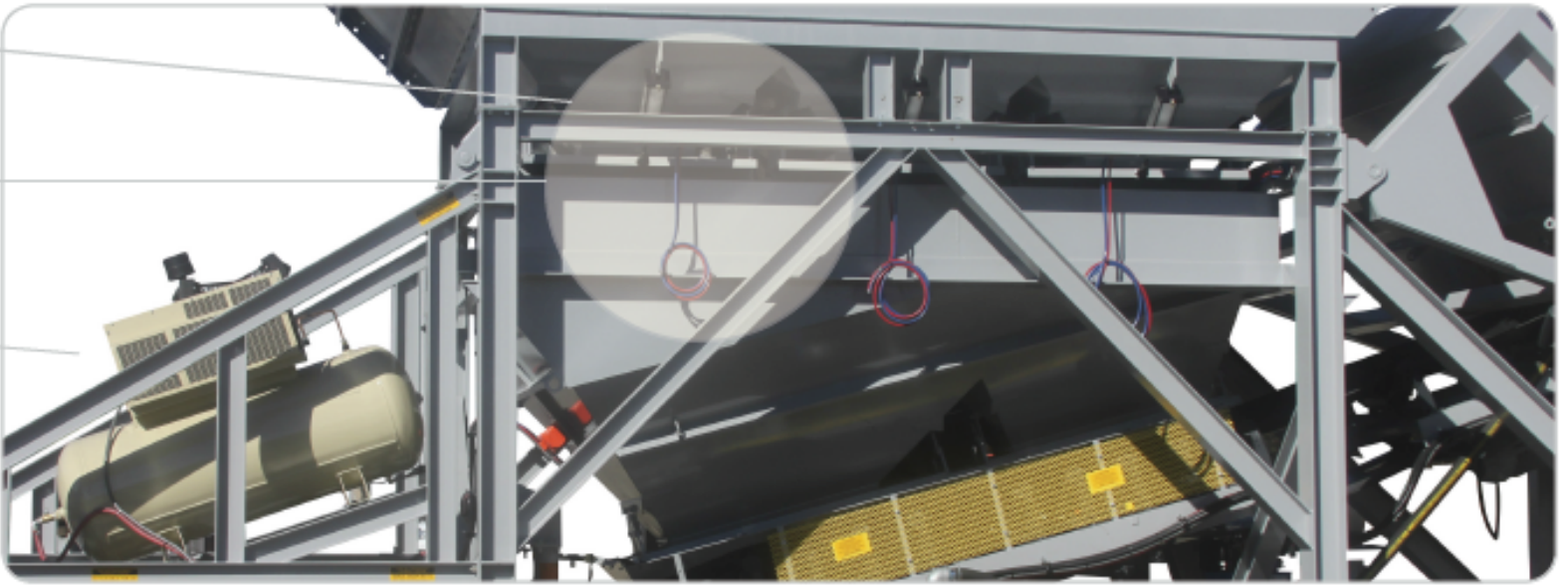

7

14 cubic yard cement batcher.

8

Optional 350 gal water holding tank.

9

Optional Tilt-up silo collectors.

10

Optional Pony Express 412 bbl Mobile Silo.

11

Gasoline engine powered hydraulic systems with 4 levelling jacks. Standard feature on Clydesdale, optional on Pony Express.



# Stephens

## CONCRETE EQUIPMENT

### Why buy a Stephens?

- Owned by the Stephens Family since 1957
- Honest, reliable, second-to-none sales & service
- In-house CNC Machine Shop
- Simple and easy to service & maintain
- Standard, off the shelf parts
- Each plant conforms to CPMB (Concrete Plant Manufacturing Bureau) criteria.



### Clydesdale Portable Batch Plant Specifications

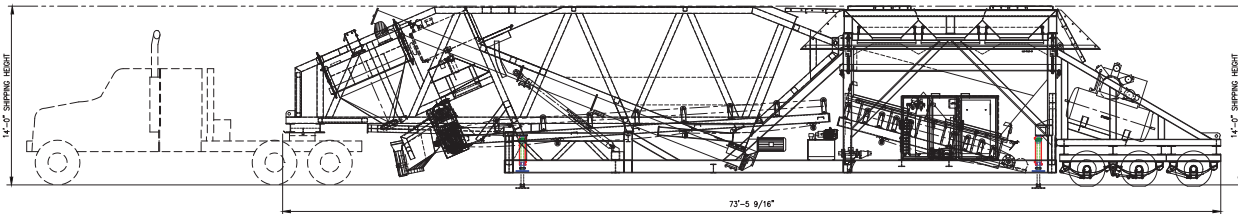

*Accumulative plant  
(tri-axle truck may be required  
in some locations)*

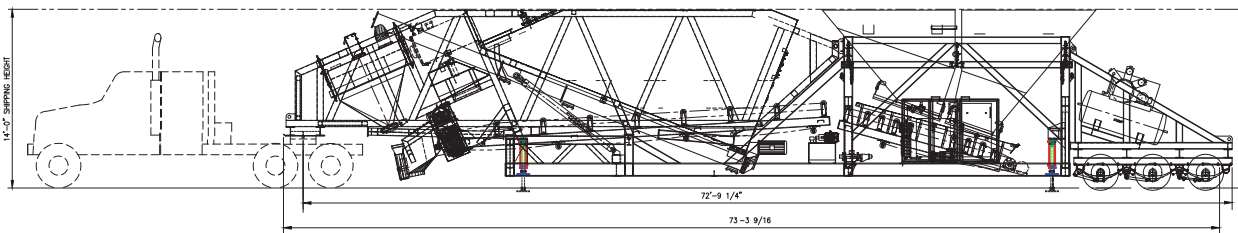
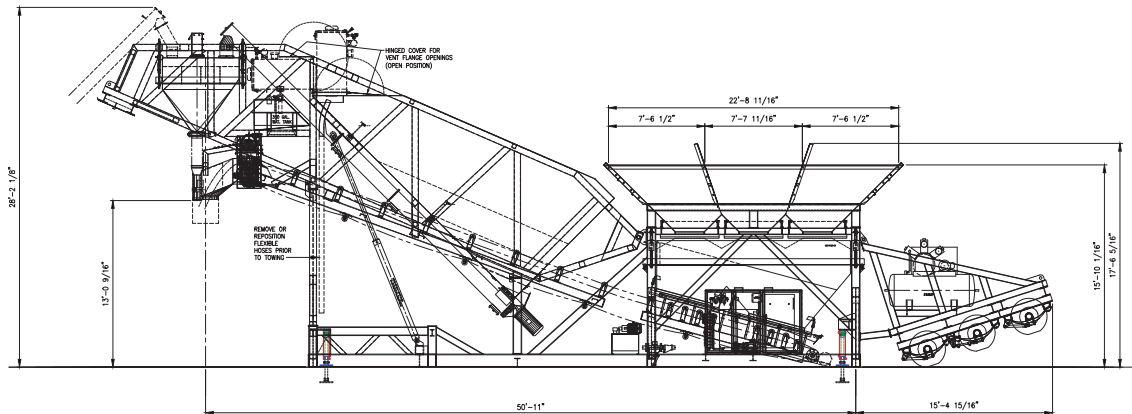

*Decumulative plant  
(tri-axle truck may be required  
in some locations)*

